

VoiceCom 2000

Owner's Manual

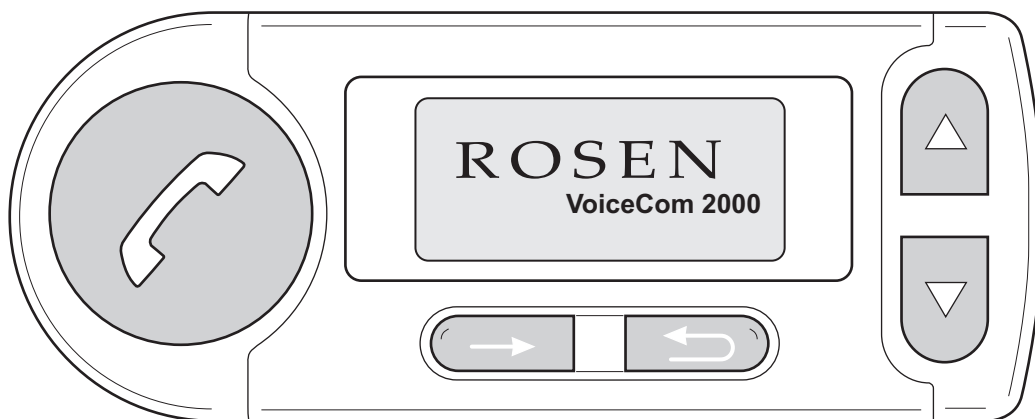

Table of Contents

Operating Instructions

1 Display and controls	3
2 First Operation	4
3 Signalling elements	5
4 Menu	6
4.1 Direct dialling	6
4.2 Messages	6
4.3 Call log	6
4.4 Phone book	7
4.5 Audio	10
4.6 Settings	11
5 User Administration	12
6 Making calls	13
7 Voice Control	14
8 Accessories and spare parts	22
9 Specifications	22
10 Software updates	23
11 Hot line	23
12 Troubleshooting	24

1 Display and controls

The *VoiceCom 2000* has 5 buttons. The following basic functions are assigned to the individual buttons.

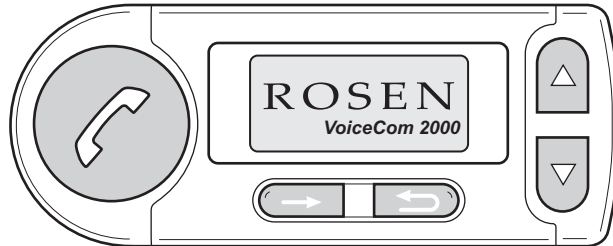

- Activates voice control when depressed for a few seconds
- Accepts incoming call
- Ends call
- Confirms yes/no queries
- Accepts highlighted elements



- Accepts incoming calls
- Opens main menu
- Selects and opens menu sub-items
- Confirms yes/no queries



- Rejects or ends call
- Leaves menu or moves up to a higher menu level
- Changes user and logs off main screen
- Deletes or aborts entry of letter or number



- Leafs through menus and phone book
- Leafs through speller
- Regulates volume during a call
- Selects yes/no

2 First Operation

The following describes the procedures to use when operating the system for the first time. An "egg timer" appears when the system is switched on. The control unit might be updated then. If so, a pocket knife will appear. After that, the Rosen logo will appear. See 10 software updating



User log-on:

- At the end of the starting procedure, the menu for language selection for the display menu appears.
- Please switch the Bluetooth in your mobile phone on and activate "visibility".
- The *VoiceCom 2000* uses the Bluetooth headset and hands-free profile.

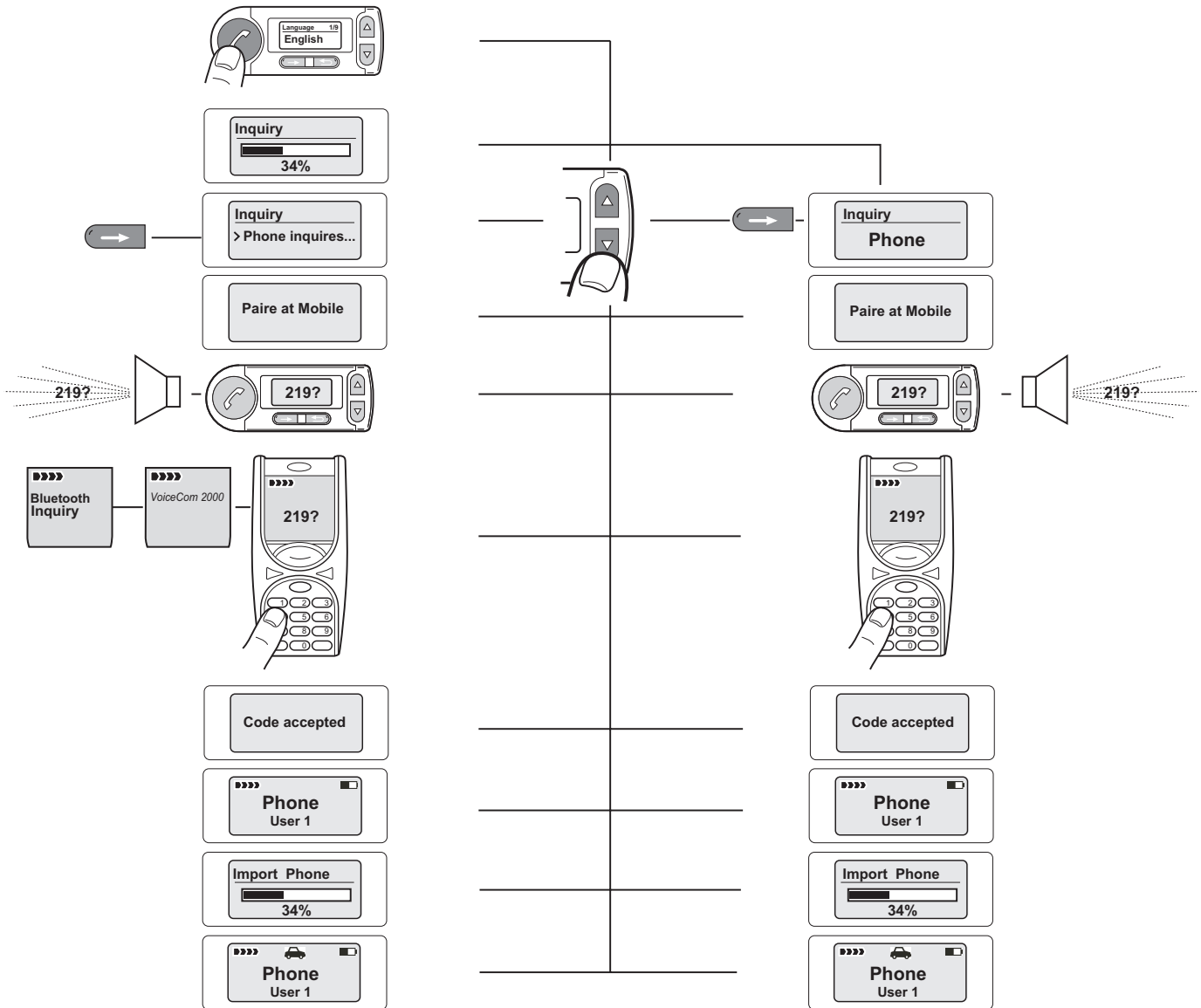

3 Signalling elements

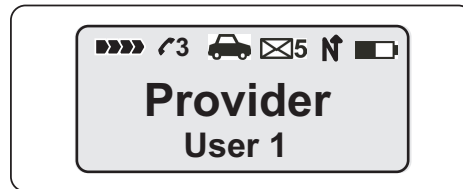

Symbols

	Field intensity display *
	Calls during absence *
	Battery charging *
	New SMS *
	Battery indicator *
	Connection in Bluetooth hands-free profile *
	Connection in Bluetooth headset profile *
	Bluetooth with user selection
	Deactivation
	Activation
	Deactivation
	Activation
	Capital letters to lower case letters
	Lower case letters to numbers
	Numbers to special characters
	Special characters to capital letters

* depends on mobile phone

4 The Menu

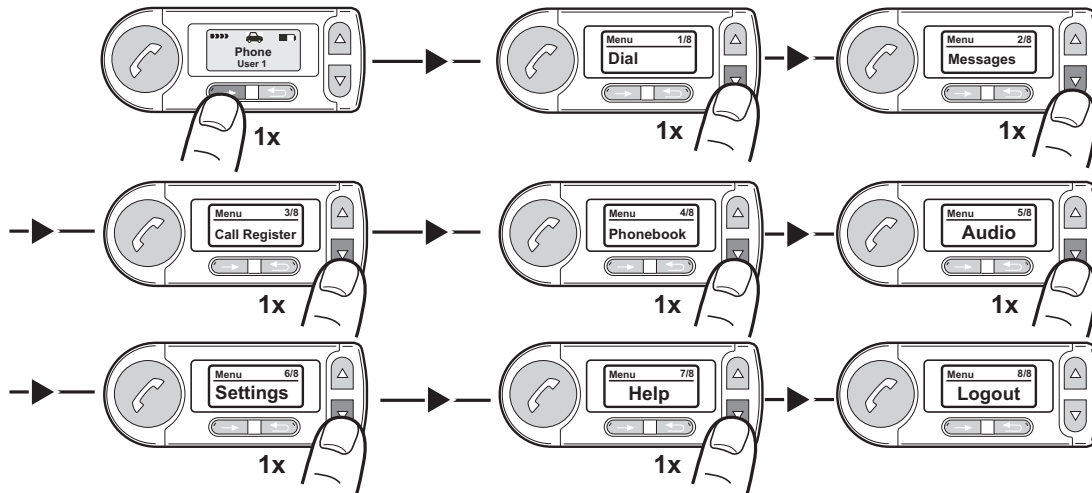

4.1 Dial

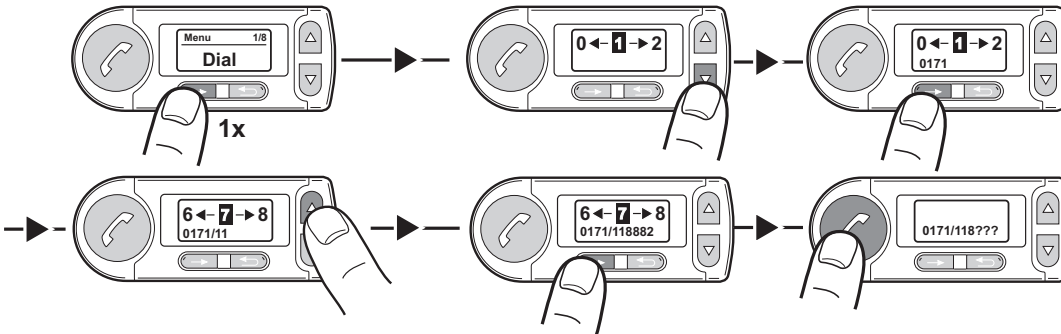

4.2 Messages

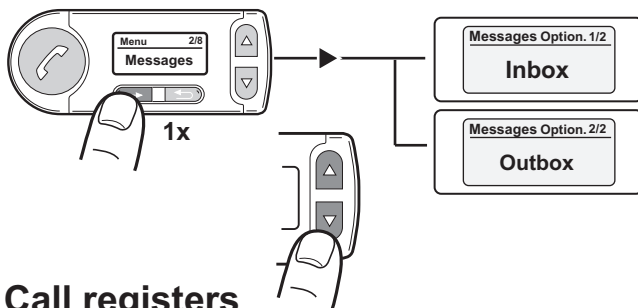

4.3 Call registers

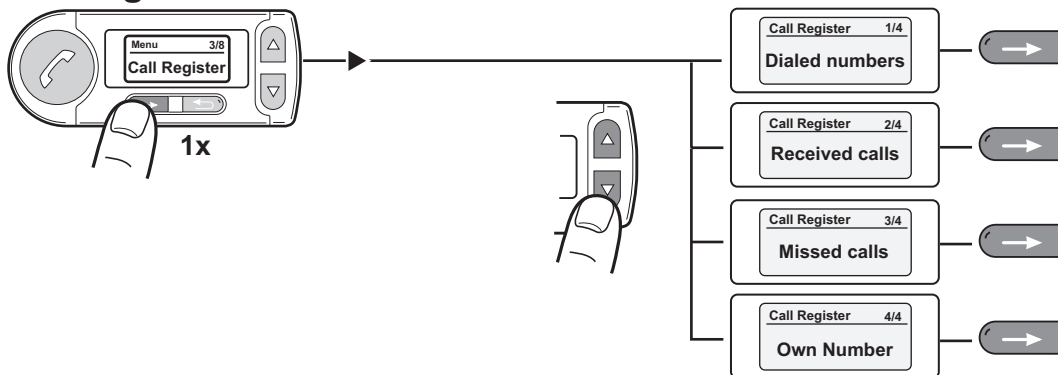

4.4 Phonebook

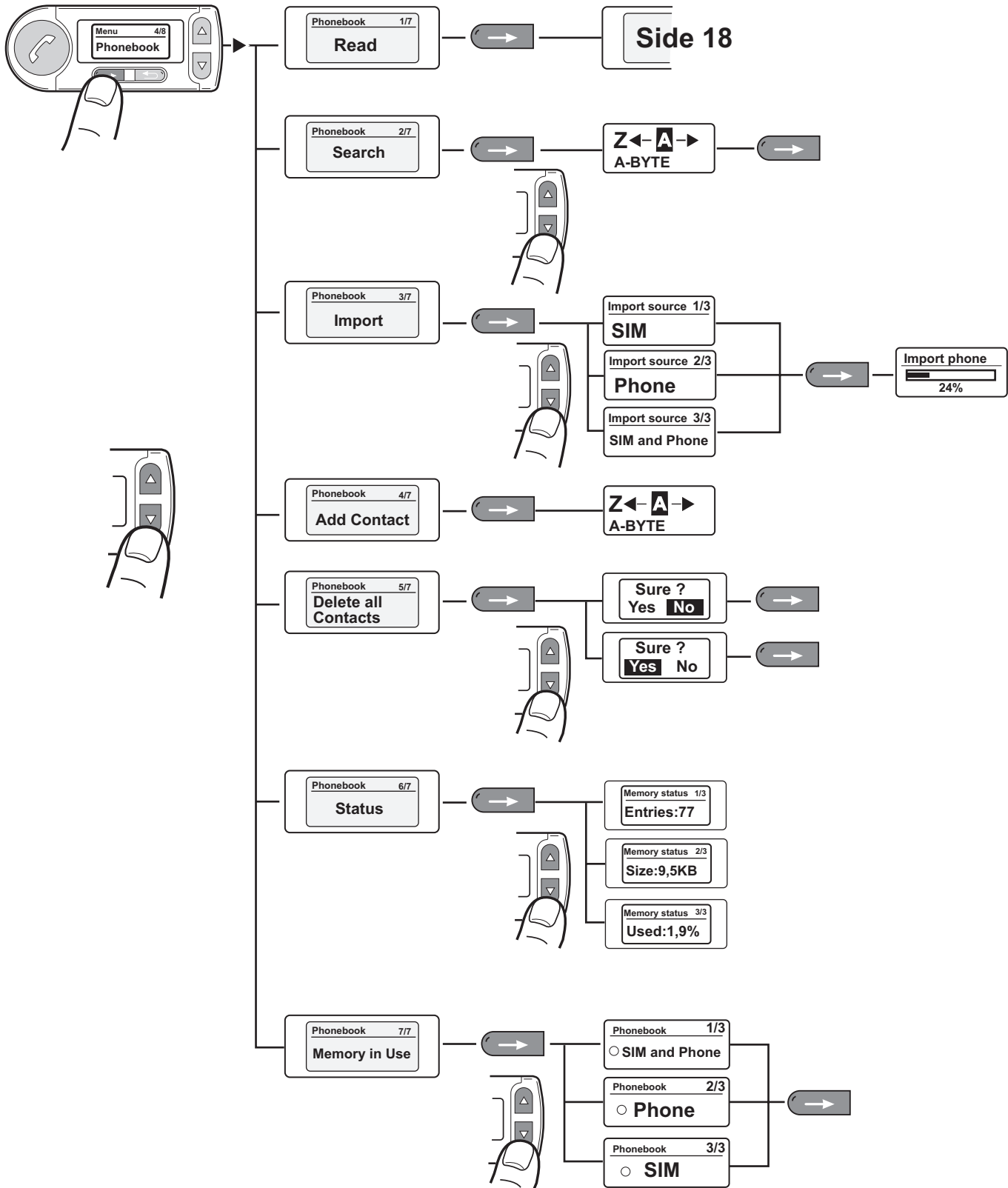

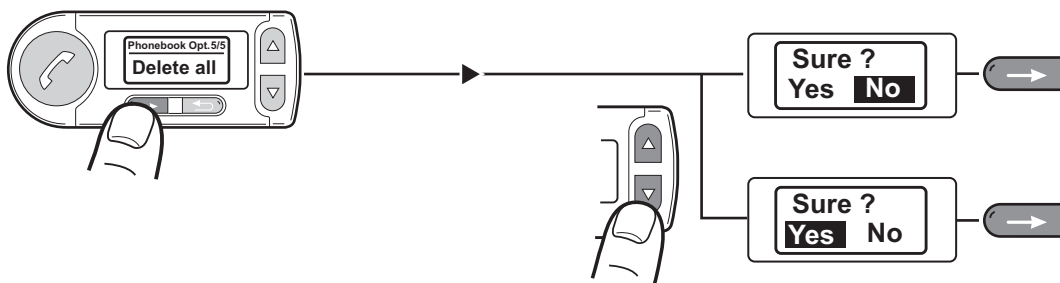
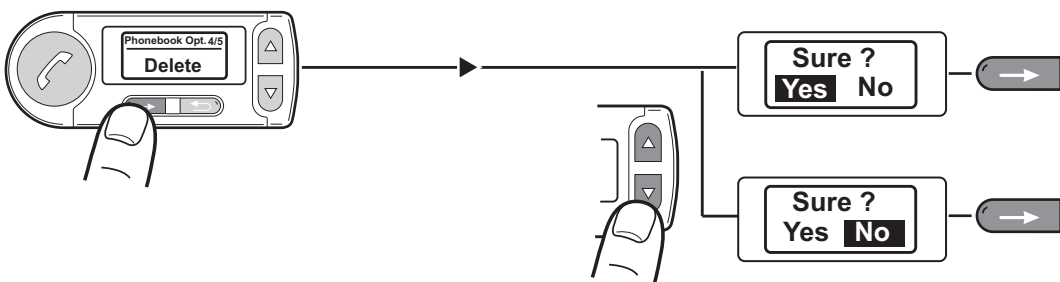
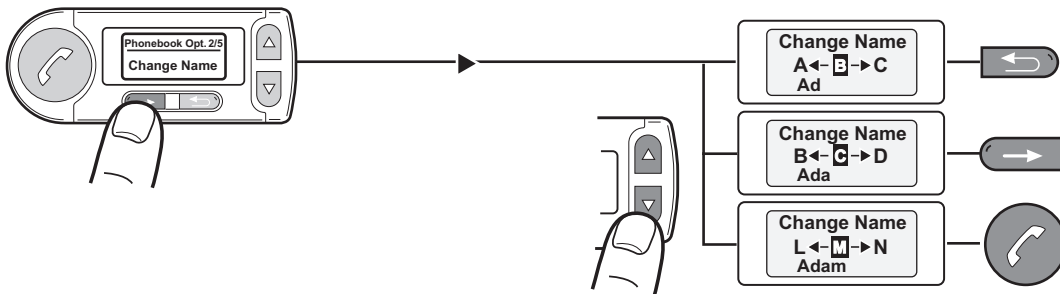
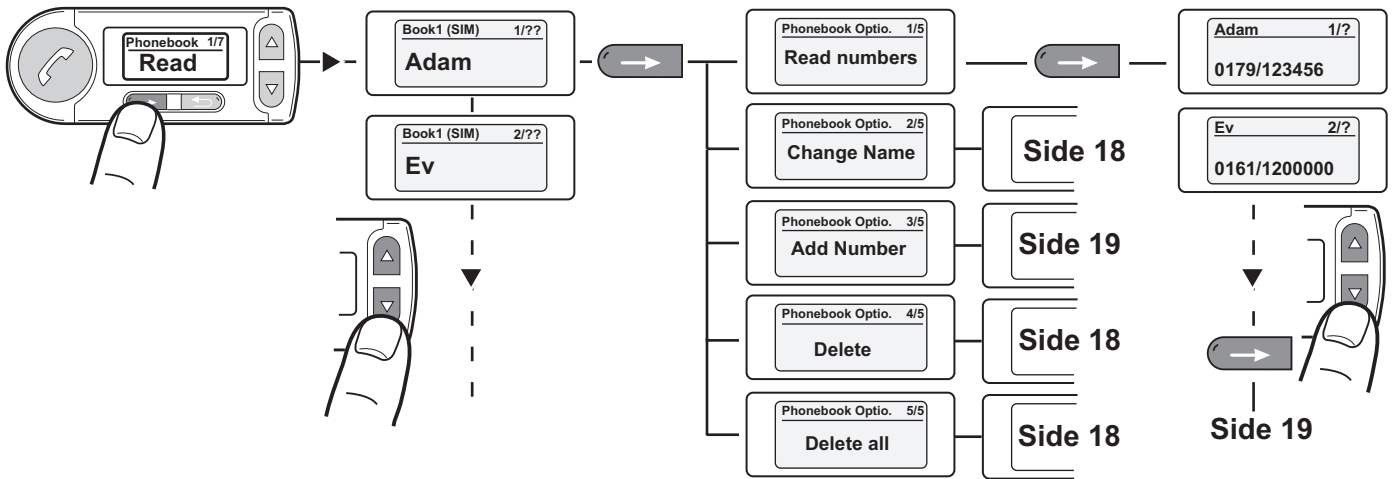

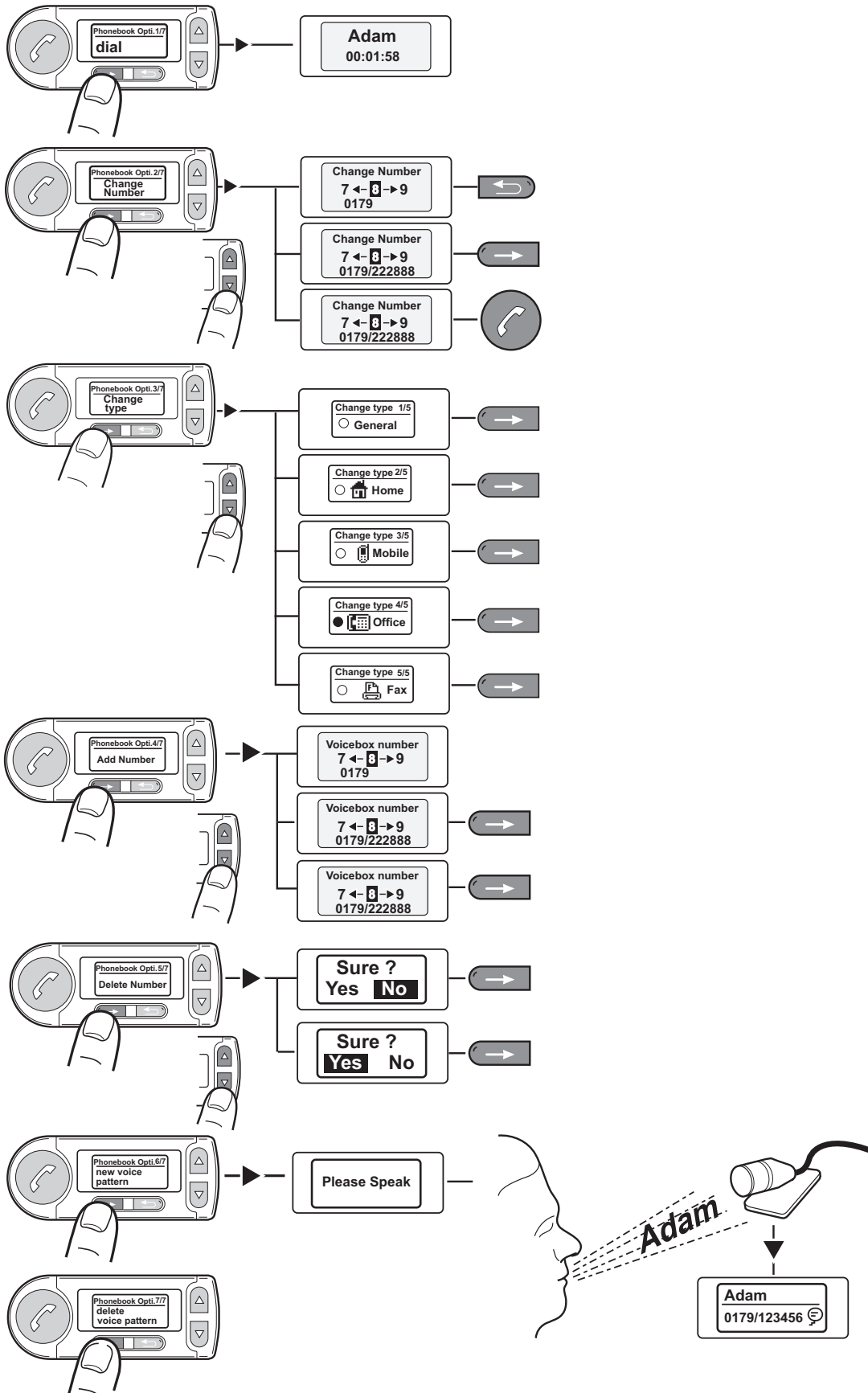

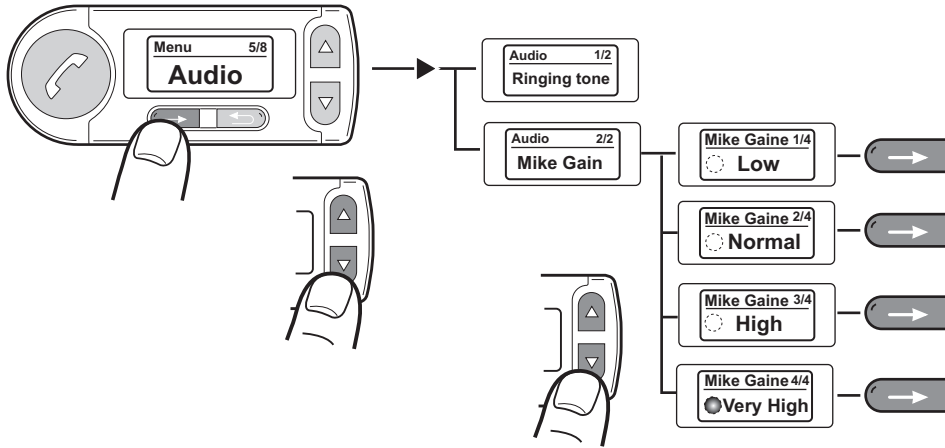

4.5 Audio

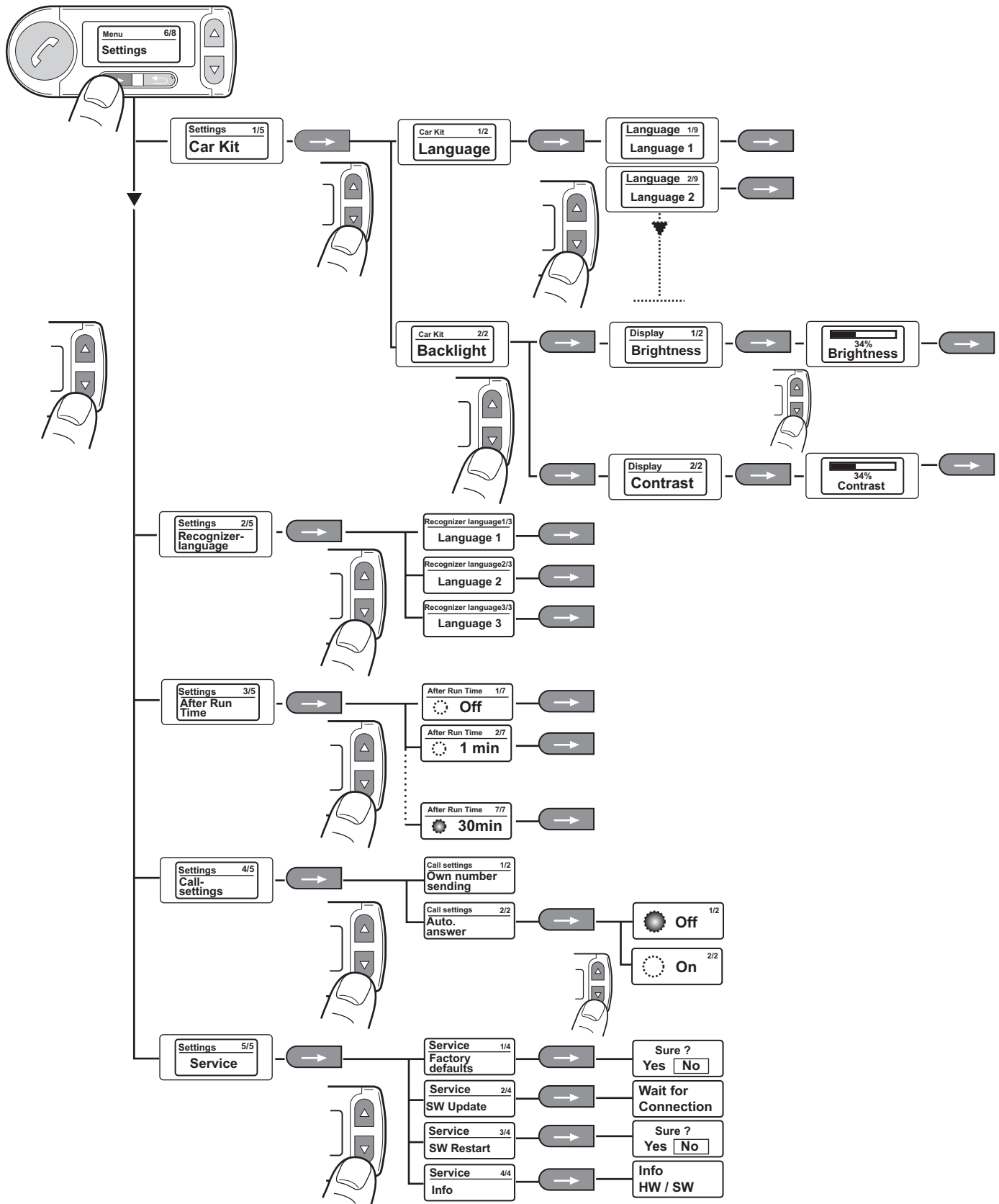

4.6 Settings



5 User Administration

- Phone book
- Bluetooth hands-free  / headset profile 
- Display brightness
- Display contrast
- Ringing tone
- Display language
- Volume setting

Open user administration:

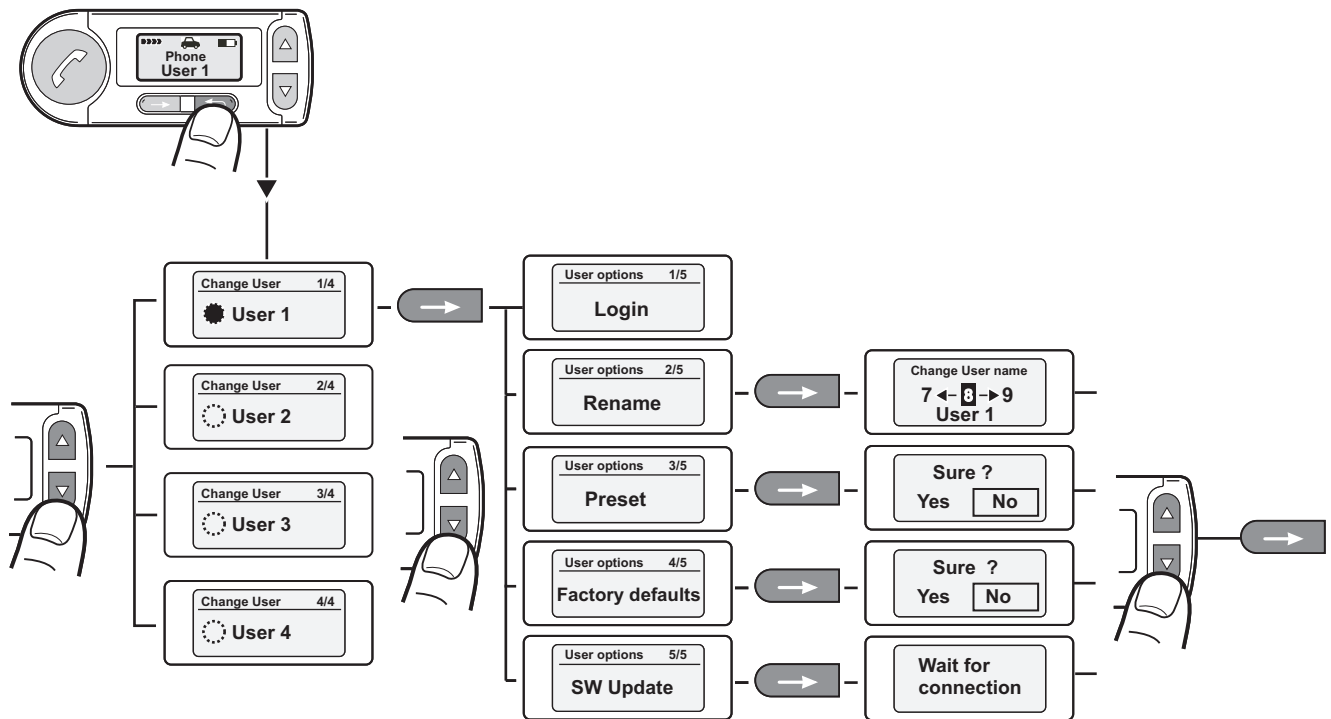

6 Phoning

Incoming Call:

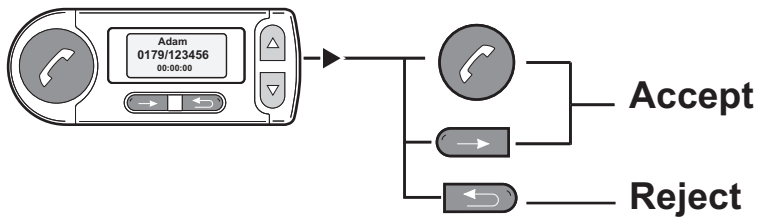

Private Mode:

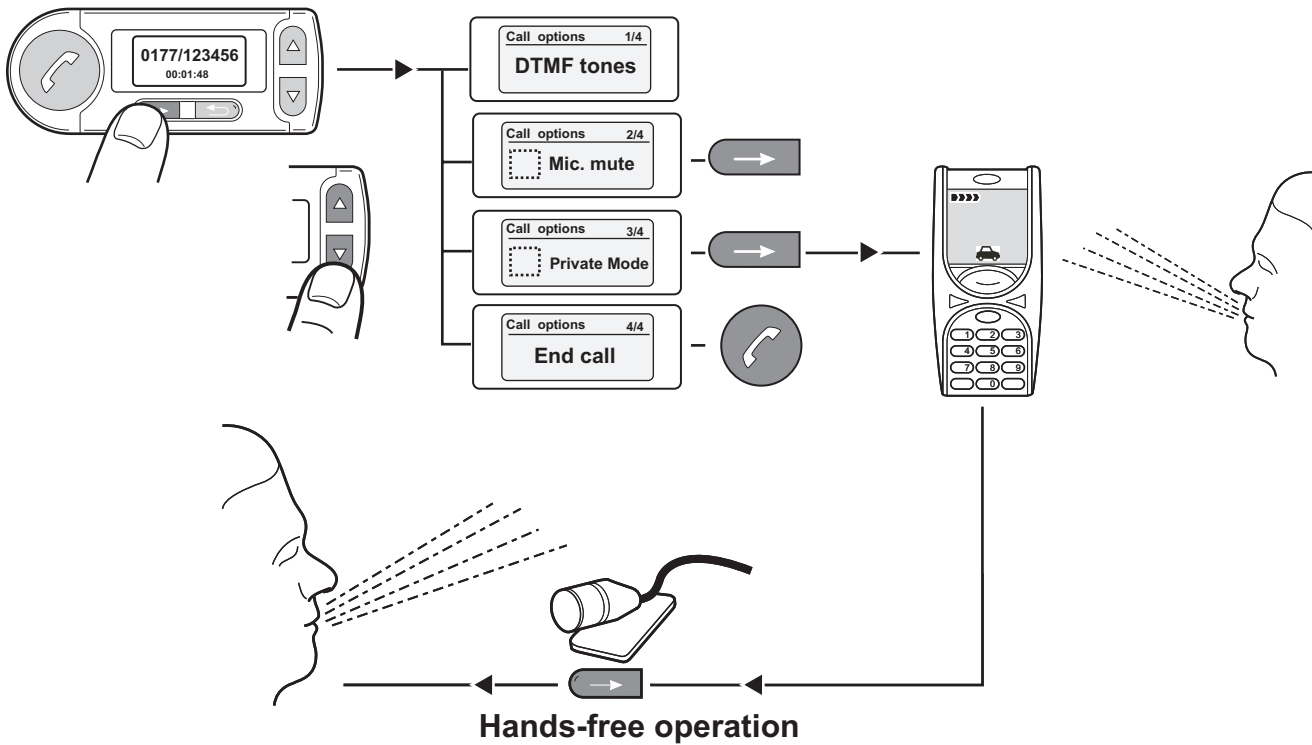

Volume setting during the call:

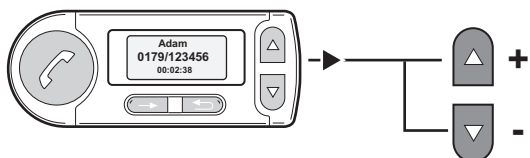

7 Voice Control

Dial number:

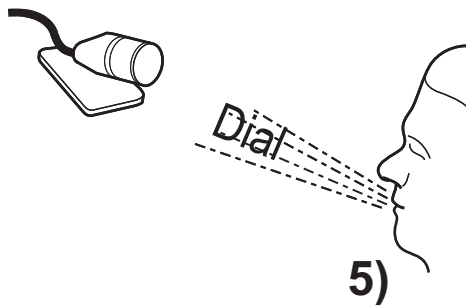
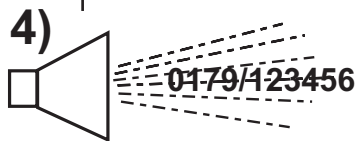
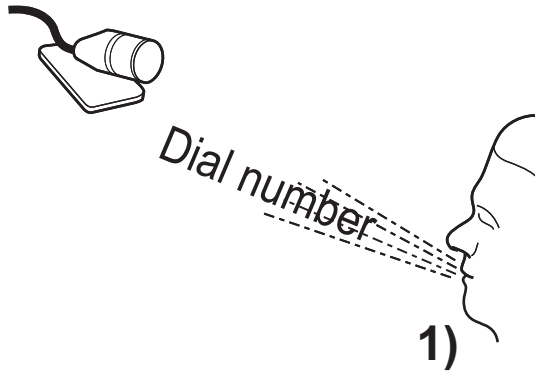
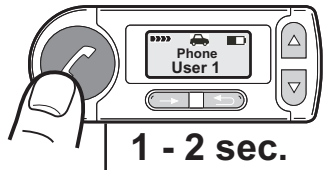

Store numbers:

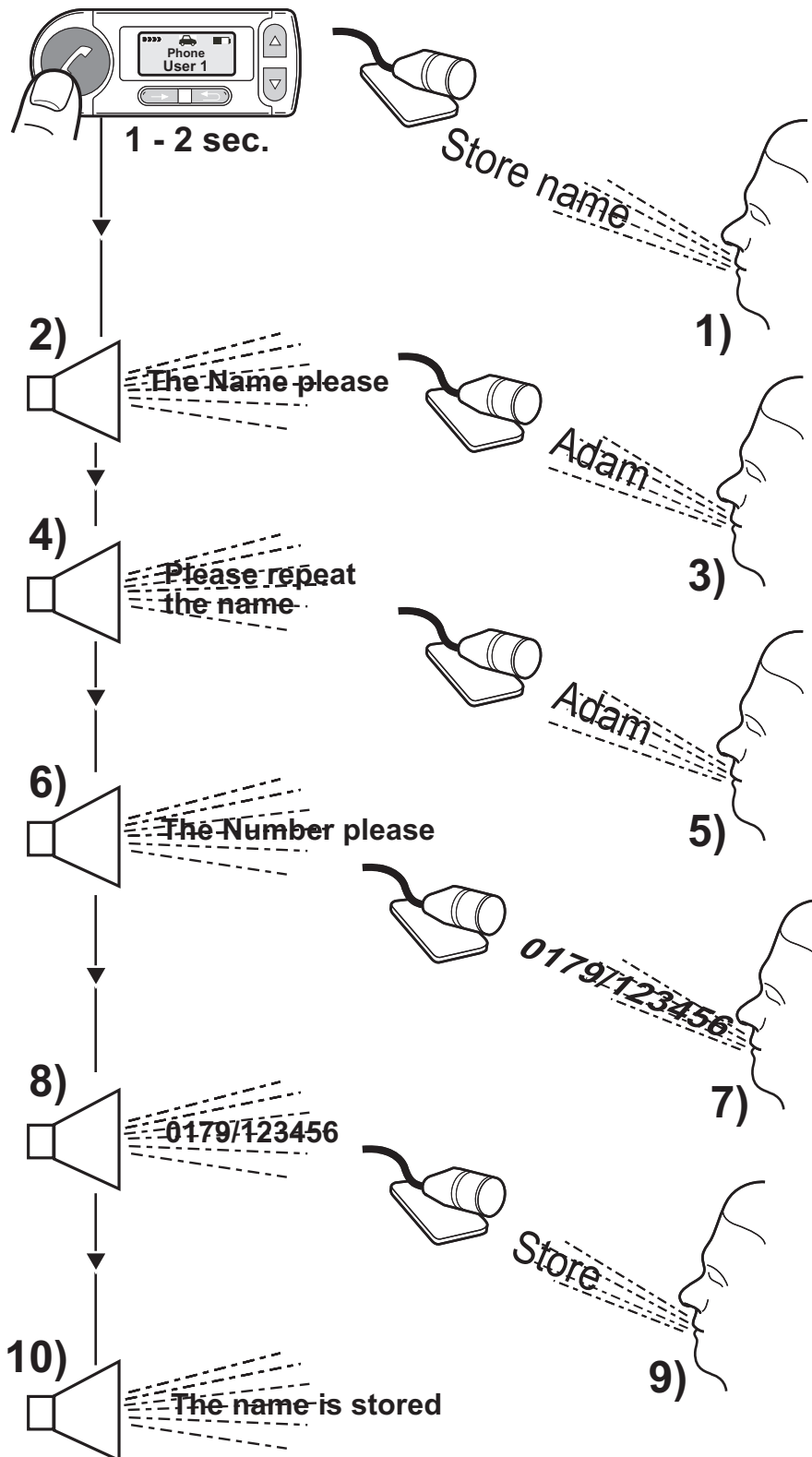

Dial name:

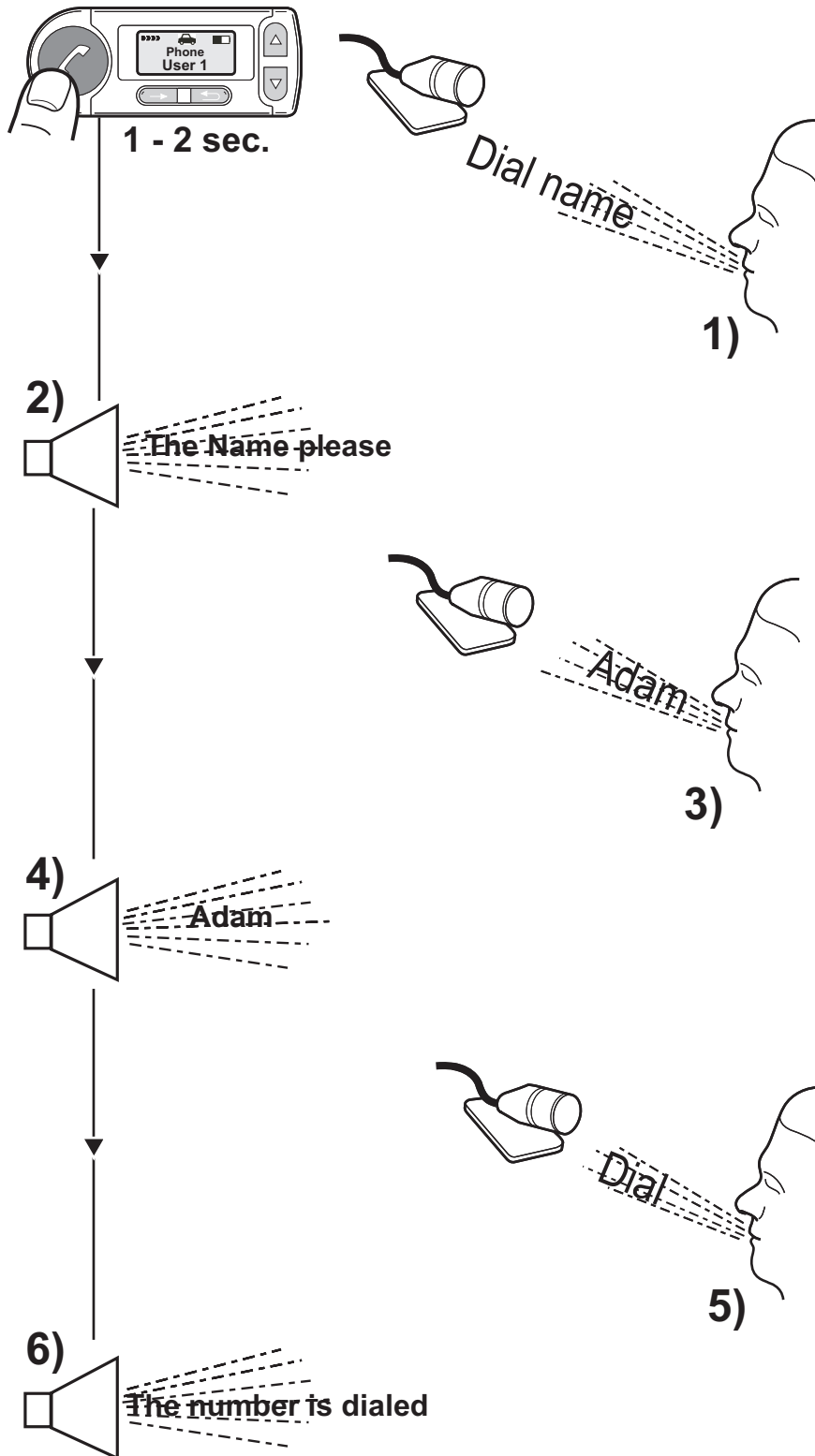

Say names:

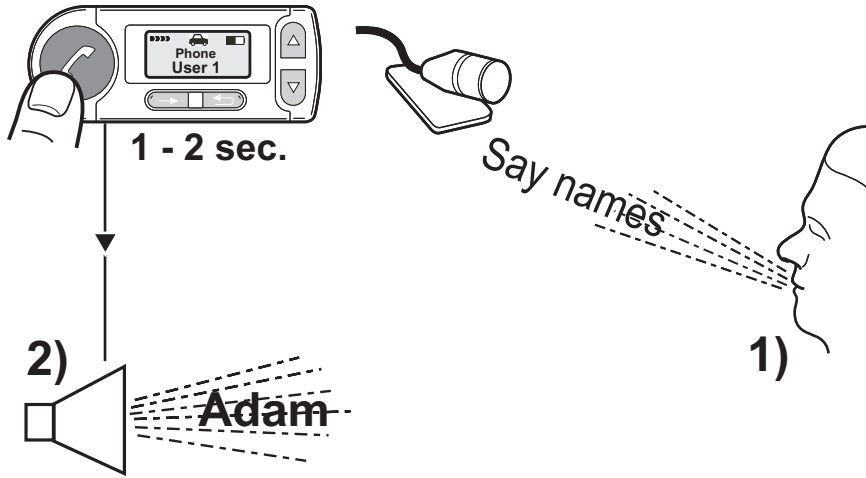

Delete names:

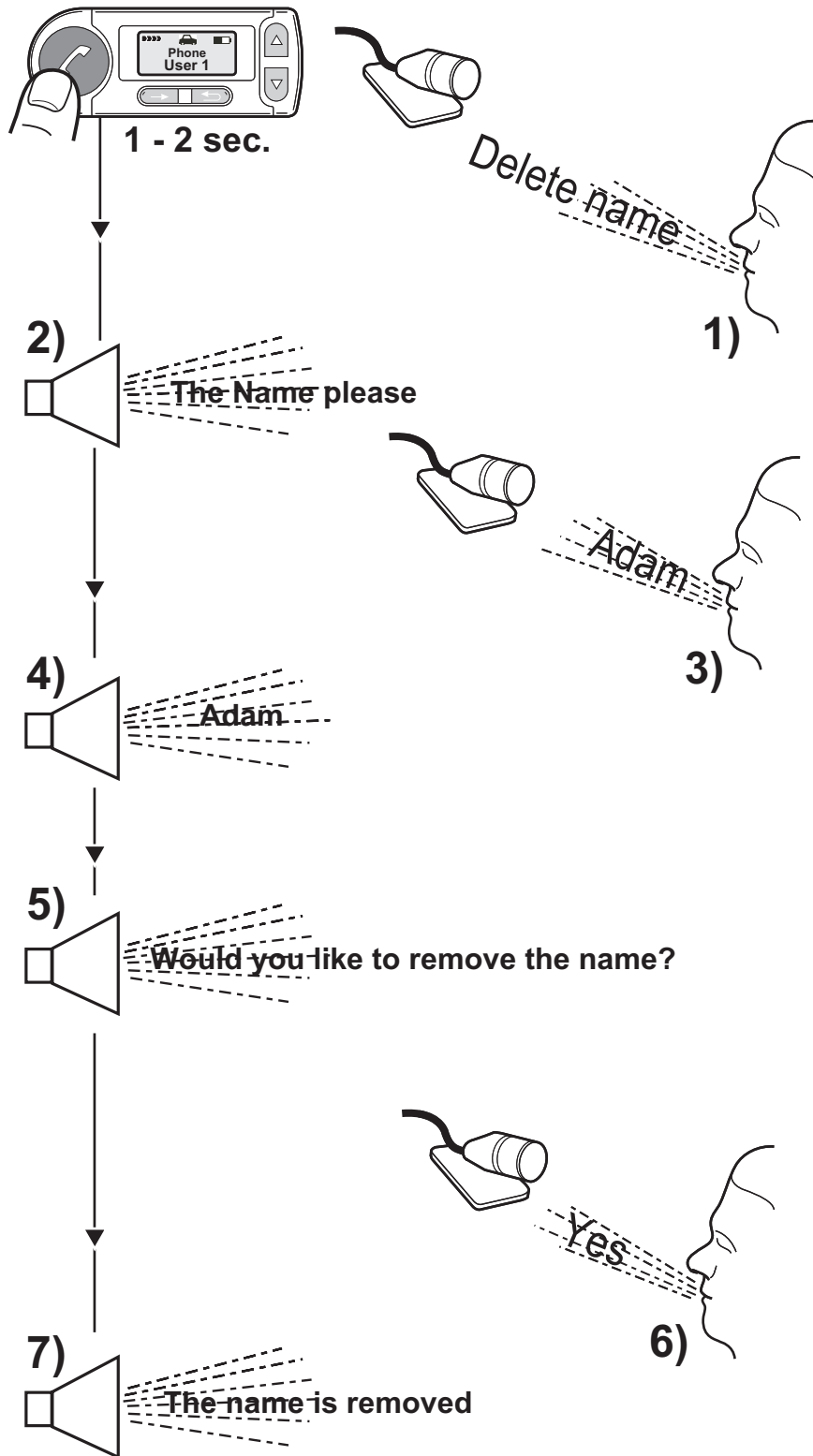

Delete all names:

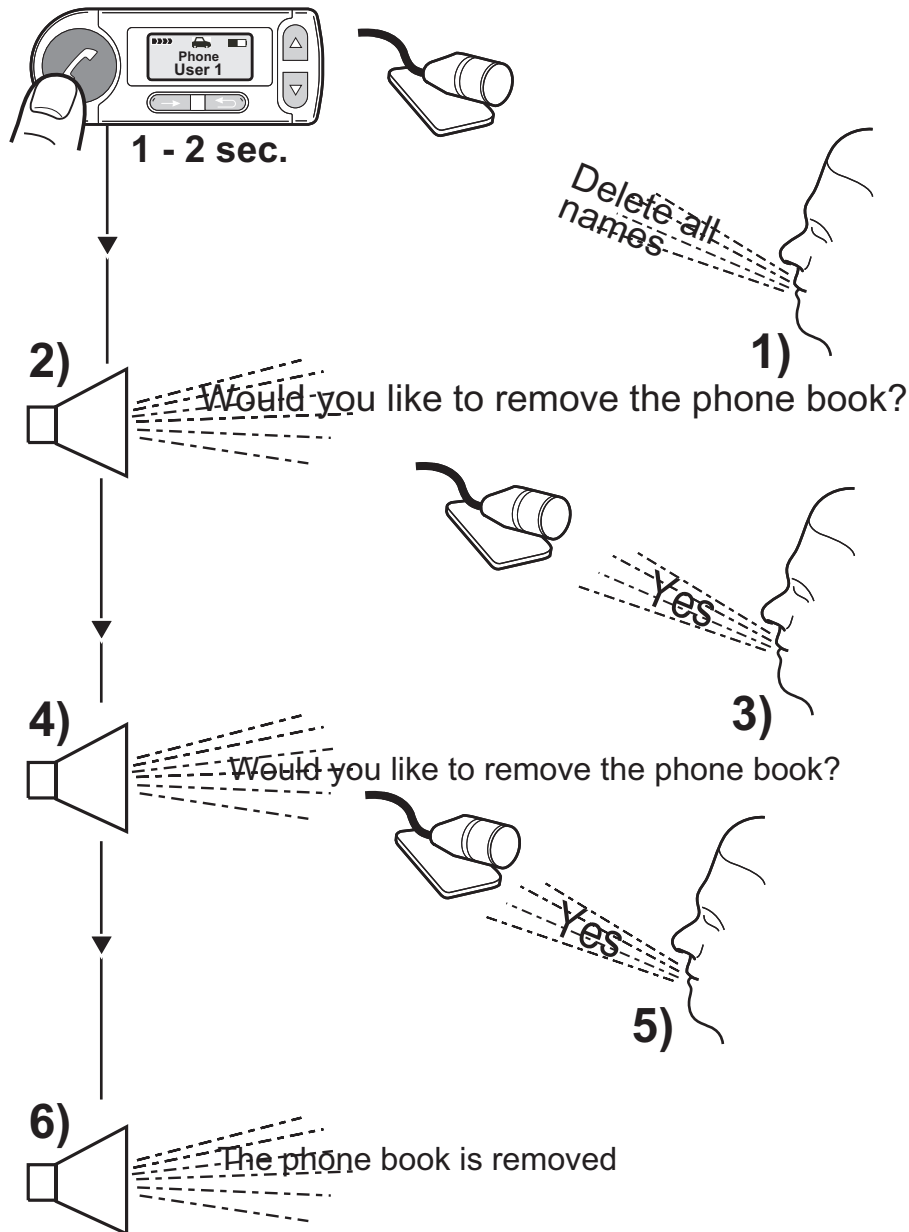

Redial:

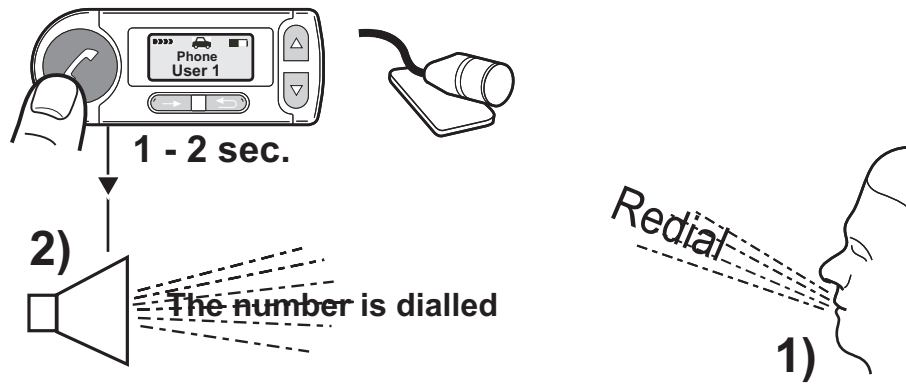

Voice Options:

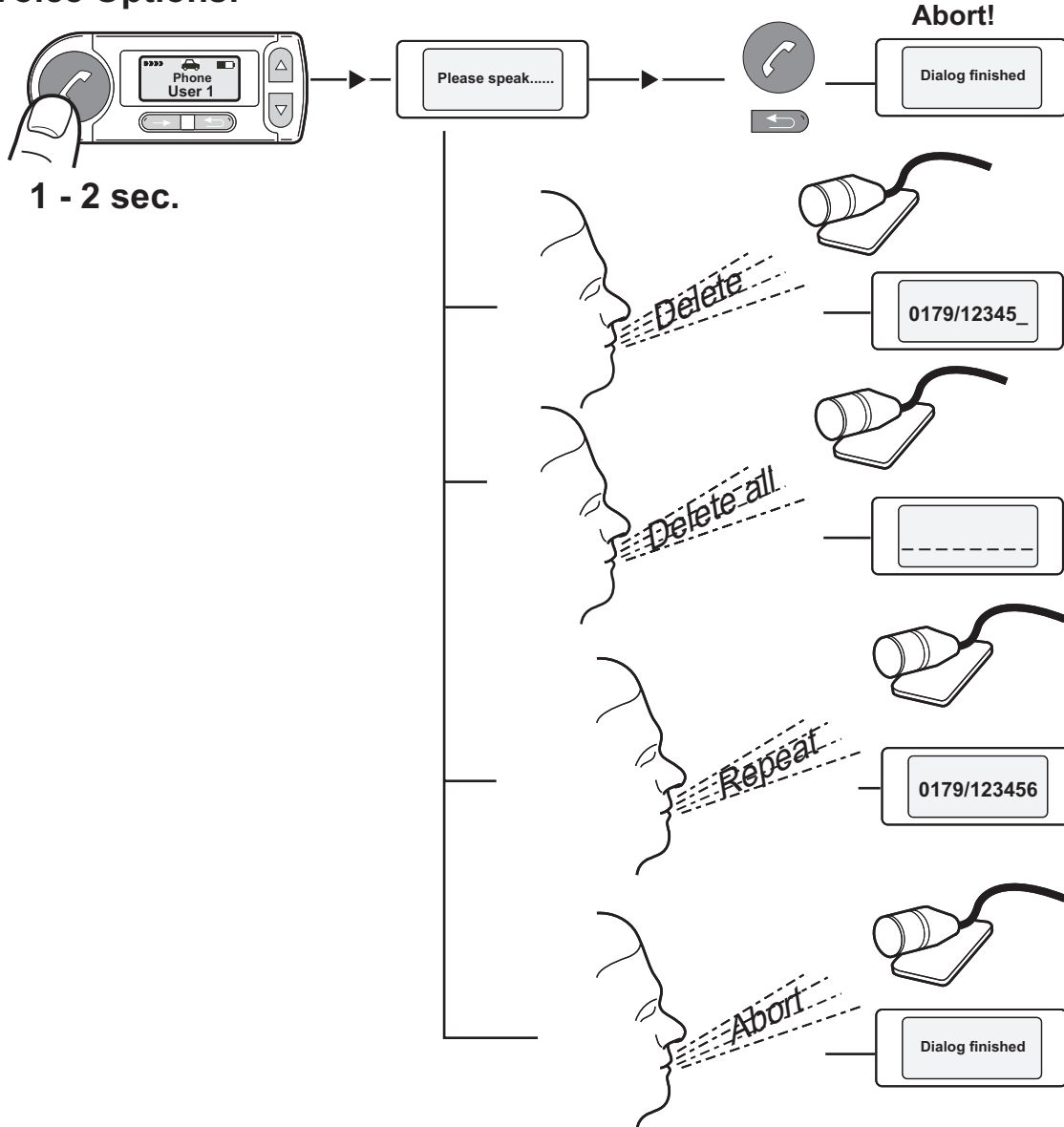

Voice Control Mobile Phone:

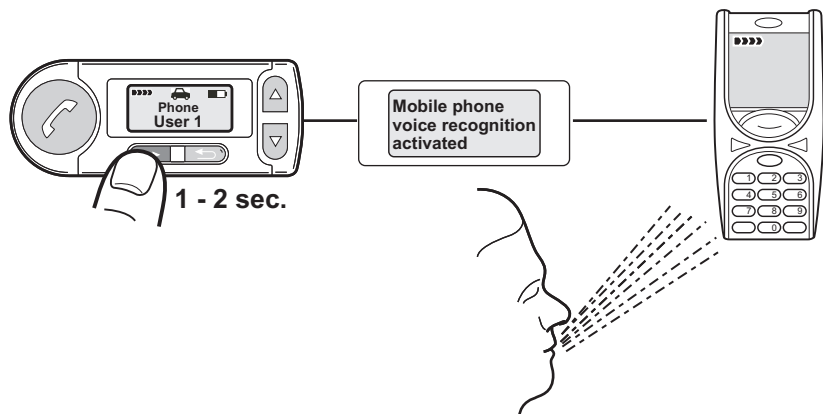

8 Accessories and spare parts

For information on the currently supported mobile phone models, visit www.rosenentertainment.com on the Internet. Your dealer will also be happy to advise you on all issues in this respect.

Spare parts:

- ① microphone (p/n 9101051)
- ② control unit (p/n 9101054)
- ③ electronics box (p/n 9101055)
- ④ connection cable set (p/n 9101053)

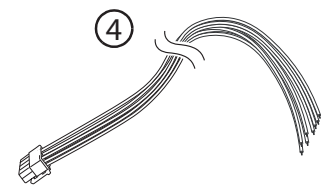
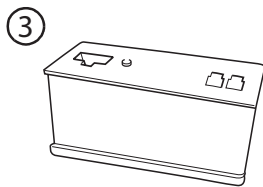
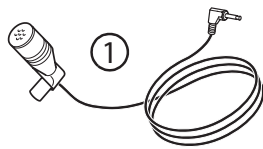

9 Technical Data

Dimensions of the electronics box	128mm x 76mm x 29mm
Dimensions of the Control Unit	90mm x 33mm x 18mm
Operating voltage	11 V to 15 V
Closed-circuit consumption	max. 0,1 mA
Open-circuit amperage	max. 750 mA
Fuse	1A and 2A
Operating temperature	-10 °C to +55 °C

Software Updating

You will find the current software under www.rosenentertainment.com

Hotline

Our technical support hotline is open Monday through Friday from 8 a.m. to 5 p.m Pacific Standard Time.

Procedure:

- Check if you can solve the problem with the aid of the "Troubleshooting" section.
- Keep the type designation of the hands-free system set to hand.
- Try to describe the problem as precisely as possible.

You can call our hotline under the following numbers:

Phone: 951.898.9808

Fax: 951.898.9897

Email: info@rosenentertainment.com

12 Troubleshooting

Problem	Cause	Remedy
VoiceCom 2000 does not switch on.	There is no supply voltage.	If necessary, replace the fuse and check the cable and connections.
	The ignition is not turned on.	Turn on the ignition.
	The ignition line is interrupted.	Check cable and 1A fuse.
The person you are calling cannot hear you.	The microphone is not inserted or the microphone cable is damaged.	Connect the microphone plug to the electronics box. If the cable is defective, it must be replaced.
The person you are calling complains about interference noise.	The microphone is in an air stream.	Mount the microphone somewhere else or perhaps reduce ventilation.
	The phone is very close to the VoiceCom 2000 parts or the car radio.	Increase the distance between your phone and the VoiceCom 2000 or radio.
The person you are calling complains about echoes	The microphone and the speaker are not far enough apart.	Increase the distance between them or reduce the volume.
	The volume is too loud or the microphone sensitivity is too high.	Reduce the volume or perhaps reduce the microphone sensitivity at the electronics box.

Problem	Cause	Remedy
During device pairing, the phone cannot find the "VoiceCom 2000."	The VoiceCom 2000 is not in the pairing mode.	Initiate the device pairing (see section on Device Pairing).
	The phone does not support the set profile.	Abort the pairing, set another device class and try again.
Unclear, scratchy sound	Bad Bluetooth® connection	Reduce the distance between the phone and the Bluetooth® adapter or remove any (metallic) obstructions.
The paired phone is not connected when the ignition is turned on.	The phone is not within range.	Bring the phone within range of the Bluetooth adapter.
	The Bluetooth® interface is deactivated in the phone.	Switch your phone Bluetooth® "on" (the "automatic" option is not enough).
	The phone demands confirmation of the connection set-up.	Confirm the connection on the phone. Deactivate the security query (see operating instructions with the phone).
	One of the two devices does not have a valid connection code any longer.	Delete the respective other device from the list of paired devices in the two devices and start the pairing process again.